

EFFECTIVE:
21-NOV-05

VERTICAL MOTORS
WITH STYLE "P" BASE
FRAME: 444, 447TP, TPA
TYPE: TU, LU

PRINT:
09-2078

SUPERSEDES:
19-JAN-01

SHEET:
1 OF 1

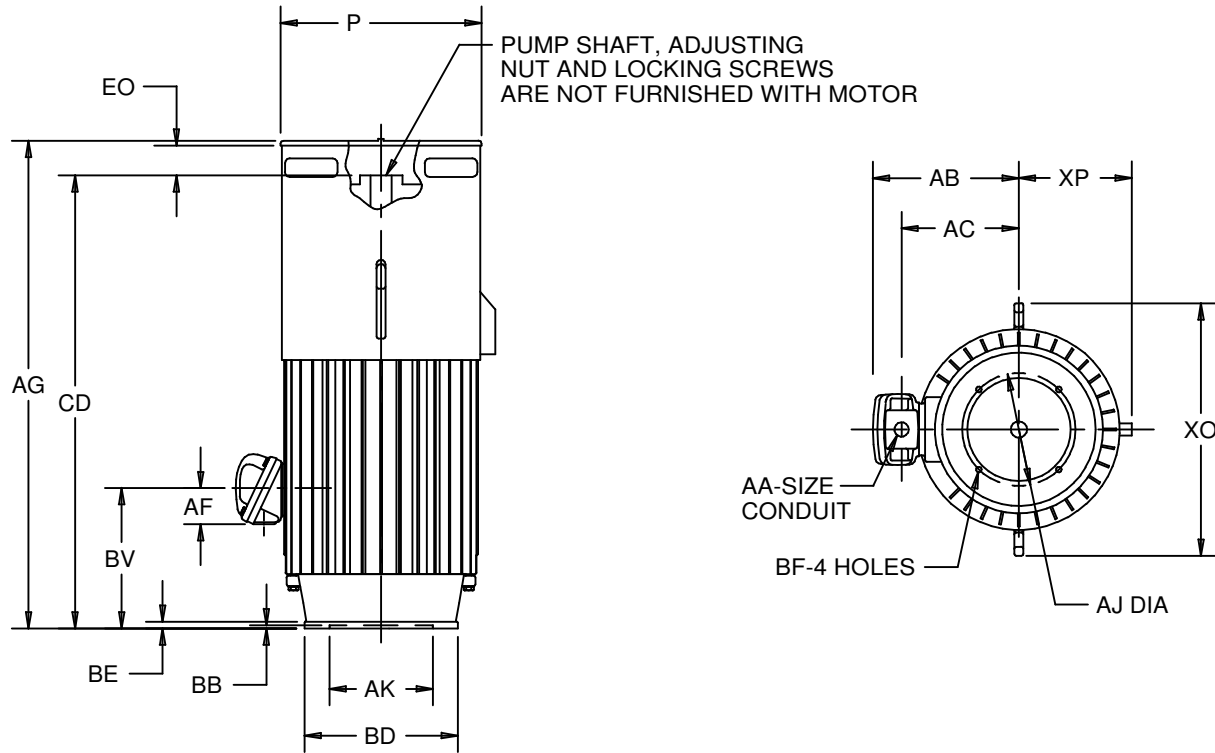

ALL DIMENSIONS ARE IN INCHES AND MILLIMETERS

UNITS	P ²	AJ	AK +.005	BB MIN	BE	BF	EO	XO	XP
IN	23.25	14.750	13.500	.25	1.00	.69	4.63	28.91	14.38
MM	591	374.65	342.90	6	25	17	117	734	365

FRAME	UNITS	AG	BV	CD
444	IN	48.13	17.13	42.50
	MM	1222	435	1080
447	IN	51.63	18.88	46.00
	MM	1311	479	1168

TYPE	UNITS	AA	AB	AC	AF
TU	IN	3 NPT	18.56	14.38	4.72
	MM		472	365	119
LU	IN		19.63	14.63	4.56
	MM		498	371	116

FRAME	UNITS	BD MAX
440TP	IN	16.50
	MM	419
440TPA	IN	20.00
	MM	508

- 1: ALL ROUGH DIMENSIONS MAY VARY BY .25" DUE TO CASTING AND/OR FABRICATION VARIATIONS.
- 2: LARGEST MOTOR WIDTH.
- 3: CONDUIT BOX OPENING MAY BE ROTATED IN STEPS OF 90°.
- 4: TOLERANCES SHOWN ARE IN INCHES ONLY.

TOLERANCES	
FACE RUNOUT	.007 F.I.R.
PERMISSIBLE ECCENTRICITY OF MOUNTING RABBET	.007 F.I.R.